

Winkel 90° I/I.

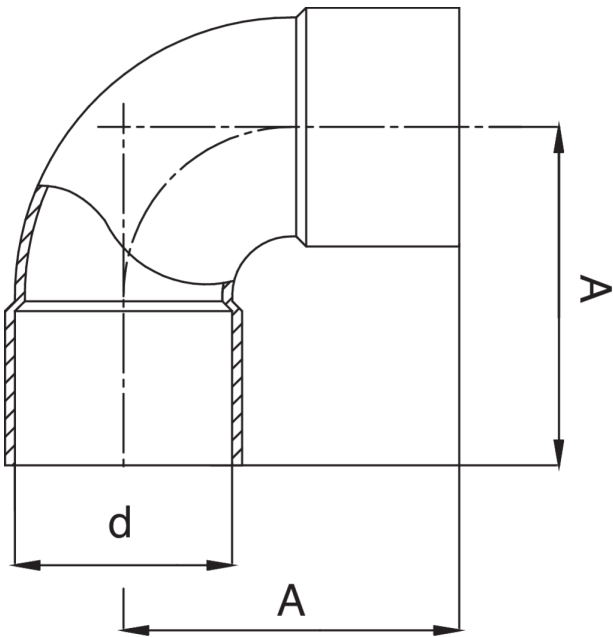

Technische Spezifikationen



D	BAG	MASTER BOX	CODE	A
6	10	1500	RR5090006006000	14
8	10	1500	RR5090008008000	16,5
10	10	800	RR5090010010000	17
12	10	500	RR5090012012000	19,5
14	10	400	RR5090014014000	23
15	25	300	RR5090015015000	25
16	10	300	RR5090016016000	24,5
18	10	200	RR5090018018000	28,5
20	10	350	RR5090020020000	27
22	10	130	RR5090022022000	33
25	10	200	RR5090025025000	30,5
28	10	60	RR5090028028000	45
32	10	40	RR5090032032000	40,5
35	5	40	RR5090035035000	52
36	5	80	RR5090036036000	42,5
40	5	50	RR5090040040000	49
42	5	50	RR5090042042000	59
52	5	30	RR5090052052000	59,5
54	1	10	RR5090054054000	60,5
63	1	6	RR5090063063000	71
64	1	25	RR5090064064000	72
66,7	1	10	RR5090067067000	72
70	1	10	RR5090070070000	72
76,1	1	8	RR5090076076000	81
80	1	10	RR5090080080000	86
88,9	1	8	RR5090089089000	92,5
108	1	5	RR5090108108000	113,5

Anwendungen



DRINKING
WATER



HEATING



HVAC



GAS



COMPRESSED
AIR



SOLAR



INDUSTRIAL