

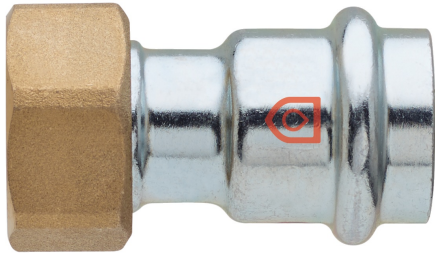

FRABO

frabo
press
C-STEEL V
ZCF359

PATENTED



Halbe Verschraubung flachdichtend.



Technische Spezifikationen

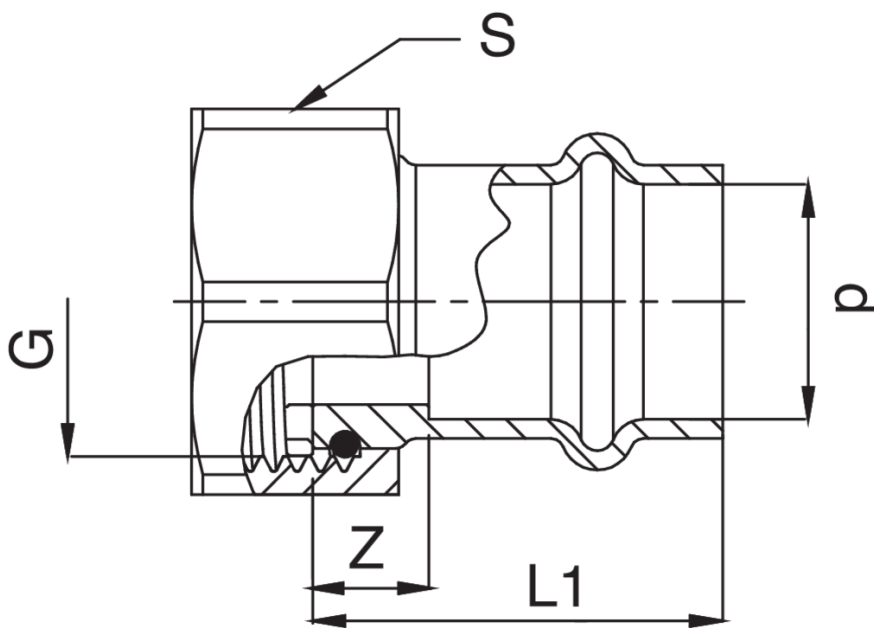

D X G	BAG	MASTER BOX	CODE	L1	S	Z
15 x 1/2"	5	100	ZCF359A12015000	44	24	22
15 x 3/4"	5	100	ZCF359A34015000	29	30	7
18 x 1/2"	10	100	ZCF359A12018000	44	24	22
18 x 3/4"	5	100	ZCF359A34018000	32	30	9
18 x 1"	5	100	ZCF359B01018000	38	37	14
22 x 3/4"	10	100	ZCF359A34022000	46	30	22
22 x 1"	5	100	ZCF359B01022000	38	37	14
28 x 1"1/4	10	50	ZCF359B14028000	34	46	9
35 x 1"1/2	5	30	ZCF359B12035000	34	46	9
42 x 2"	5	20	ZCF359C02042000	48	64	12
54 x 2"1/2	1	10	ZCF359C12054000	45	85	5

Anwendungen



HEATING



HVAC



COMPRESSED
AIR