

Kappe I.

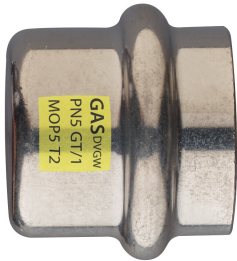

Technische Spezifikationen

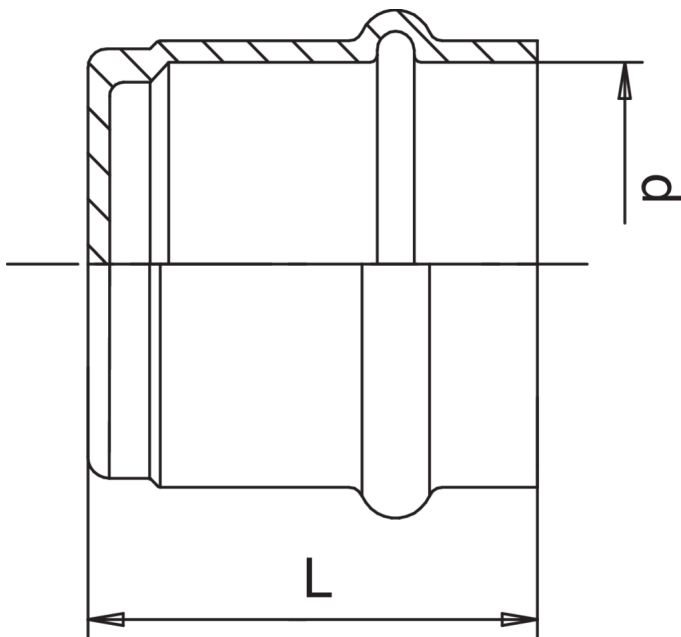

D	BAG	MASTER BOX	CODE	L
15	10	200	GX0302015000000	25
18	10	150	GX0302018000000	26
22	10	100	GX0302022000000	27
28	10	100	GX0302028000000	28
35	5	40	GX0302035000000	44
42	5	20	GX0302042000000	54
54	1	30	GX0302054000000	63

Anwendungen



GAS



COMPRESSED
AIR



INDUSTRIAL