

T-Stück reduziert symmetrical Seite I/I.

Technische Spezifikationen

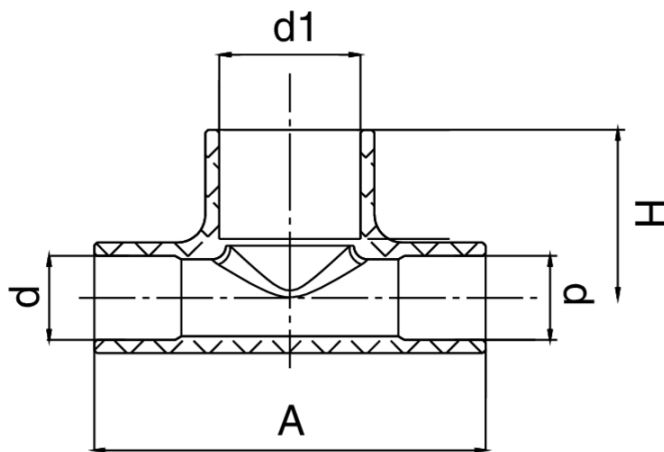

D X D1 X D	BAG	MASTER BOX	CODE	A	H
18 x 22 x 18	10	100	RG5130018022018	32	30
22 x 28 x 22	5	50	RG5130022028022	37	35
28 x 35 x 28	5	25	RG5130028035028	42,5	40
35 x 42 x 35	5	10	RG5130035042035	48	49
42 x 54 x 42	2	8	RG5130042054042	61,5	60,5
42 x 64 x 42	1	5	RG5130042064042	82	72
54 x 67 x 54	1	8	RG5130054067054	90	80
64 x 76 x 64	1	8	RG5130064076064	100	80

Anwendungen



GAS



COMPRESSED AIR



SOLAR



INDUSTRIAL



REFRIGERATION



DRINKING WATER



HVAC